

Rad-Hard Adjustable Sample Rate ADC, 12-bit, Ultra-Low Power

InstaCell™ Semiconductor IP

Features and Benefits

- Pipeline architecture
- 40 MSPS sampling speed
- 12 bits resolution (10 bits ENOB)
- Rad-hard to >3.5 Mrad TID
- Rad-hard to >120 MeV-cm²/mg SEL
- Low power, 22.5 mW
- Thin-oxide 130 nm SiGe
- IBM 8HP high performance fabrication process
- Input analog bandwidth 50 MHz
- INL <1.5 LSB, DNL <0.95 LSB
- Sleep mode reduces power to 9 mW

General Description

This innovative analog-to-digital data converter (ADC) combines high resolution, high sampling speed, and low power, and it is designed for high levels of radiation hardness. The ADC is hard to total ionizing dose (TID) of up to 3.5 Mrad(Si), and is immune to single-event latchup (SEL) and single-event functional interrupt (SEFI). Latency is below 100 ns, and power dissipation is 22.5 mW.

Ridgetop achieved high radiation hardness and performance levels using the IBM 8HP SiGe process.

The die is 4.6 x 4.6 mm, in a 48-pin QFN package. The pin-programmable sleep mode reduces power to 9 mW when idle.

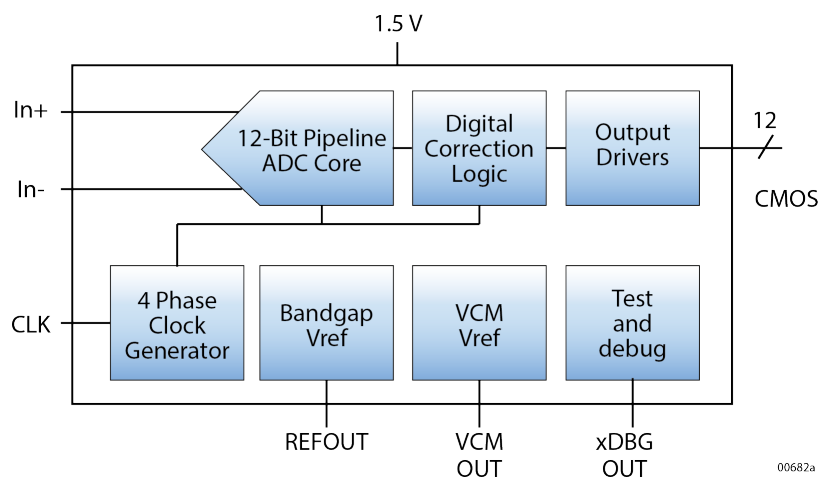

Diagram of 12-bit 40 MSPS rad-hard ADC block

Preliminary Specifications of RGADC-12B-40M-RH

PARAMETER	SPECIFICATION
Topology	Pipeline
Resolution	12 bits
Sampling speed	40 MSPS
Power consumption	22.5 mW
Power in sleep mode	9 mW
Input analog bandwidth	50 MHz
Digital output data format	CMOS
Analog supply voltage	1.5 V
Digital supply voltage	1.5 V
Digital I/O supply voltage	1.5 V
Analog input voltage	± 1 V differential input
Input capacitance	1.5 pF
Input reference voltage	1.2 V
Input voltage range	0 to 1 V
Temperature range	0 to 70 degrees C
Latency (# clock cycles)	3.5
INL	<1.5 LSB
DNL	<0.95 LSB
Area	4.6 mm ²
Process	Thin-oxide SiGe
Foundry*	IBM 8HP
Radiation hardness**	TID: >3.5 Mrad, SEL: >120 MeV-cm ² /mg
THD	-62 dB
ENOB	10
Power supply tolerance	$\pm 5\%$

*May be ported to other foundries or nodes

**IP may also be available in non-rad-hard form



*Ridgetop is AS9100C/
ISO9001:2008 certified
and has Trusted IC
Design Supplier
accreditation from U.S.
Defense Microelectronics
Activity (DMEA)*

Sub-blocks are also
available as separate IP

Applications

The full ADC and its constituent IP blocks can be used to achieve the highest level of performance in many applications including:

- Government and commercial space microelectronics applications
- Medical imaging devices
- Defense applications such as missile control
- High-energy physics (HEP) experiments
- X-ray cargo scanners
- Nuclear stockpile monitors

Need modified or custom design? Contact Ridgetop at +1 520-742-3300 to discuss your ideal solution!

Copyright ©2014 Ridgetop Group Inc. All rights reserved. Other products mentioned may be trademarks or registered trademarks of their respective holders. The information contained herein is subject to change without notice.

Corporate Headquarters

3580 West Ina Road
Tucson, Arizona 85741 USA
OFFICE +1 520 742 3300
INFO@RIDGETOPGROUP.COM

Worldwide Locations

Ridgetop Group Inc. has support and sales locations in Belgium, Japan, China, Taiwan, South Korea, India, and the United States.
For office locations and contact information, please call the corporate headquarters or visit us on the web: www.ridgetopgroup.com